

IP Control Center N 152

5WG1152-1AB01

Product and function description



The IP Control Center N 152 is a device for DIN-rail mounting.

It offers the following functions:

- A web server for operating and observing KNX systems is incorporated in this device.
 - Standard web browser displays the operating pages, (see application program description)
 - A graphics web editor projects a fully graphic view with control and display elements in various styles.
 - Application modules:
 - Time switch schedules with up to 300 time switch commands per week
 - Scenes module with up to 5000 scenes or events
 - Full graphic Logic module with up to 1000 Logic functions
 - Alarm function with up to 250 different alarm messages
 - Email function with up to 20 contacts
 - Chart module for recording and displaying up to 10 data points in diagrams
 - Monitoring as a service tool for the analysis of up to 1000 events on the KNX bus
 - Control of up to 20 IP devices, such as beamers, routers, audio/video, heating systems, via TCP/UDP commands
 - Data point management for viewing, managing, editing, and categorizing all available data points
 - Module for controlling SONOS loudspeakers
 - Module for controlling the Philips HUE LED lighting system
- are configured via a graphics web editor.

- An additional smart editor allows the intuitive and quick preparation of simple visualisations for smartphones with mobile browser or for room control units.
- It provides an interface to KNX installations via data networks, using the Internet Protocol (IP). Concurrently, this device provides communication from KNX devices with PCs or other data processing equipment (KNXnet/IP tunnelling).

The device is configured with the settings using ETS. It defines the data types for the 250 available KNX communications objects and provides basic information for the device and for network settings.

The following data types can be chosen at the parameter setting of the communication objects:

- 1 bit
- 1 Byte (0...100%)
- 1 Byte unsigned
- 1 Byte signed
- 2 Byte unsigned
- 2 Byte signed
- 2 Byte float
- 4 Byte unsigned
- 4 Byte signed
- 4 Byte float
- 14 Byte text

Further 1000 group addresses can be linked together directly with the visualisation components.

The following default settings can be placed on the device:

- The IP address of the device is assigned by ETS configuration or automatically by a DHCP service in the IP network. Assigning of the IP address by a DHCP service allows changes to the IP address without configuring the device with the ETS.
- When configuring the device with a fixed IP address and subnet mask, a standard gateway or router can also be defined. This gives subscribers the opportunity to access the Internet or another network.

If you have queries on setting the parameters IP address of the device and subnet masks, as well as DHCP, you should contact your local network administrator.

- You can set the port number of the integrated web server.
- Web pages for viewing and the web editor can be protected separately with different passwords.

IP Control Center N 152**5WG1152-1AB01**

- The device can be set both as a time master (synchronisation by time server via IP) and as a time slave (synchronisation by KNX telegrams).
- A further parameter sets a read requirement. This will send an update to the object values after a restart/bus reset.

The device is delivered with a preset IP setting:

Delivery status:
IP address: 192.168.1.133

A Connection Manager is used as a link between the IP Control Center and the configuration PC. The Connection Manager installs the editors for project engineering on the PC. The editors are started via the Connection Manager (see application program description).

All settings for the IP Control Center, such as IP configuration, SMTP server, security and password protection, certificates, Sonos module and restart, are centrally managed via a separate configuration page (see application program description).

Note

Siemens urgently recommends that you use firmware updates as soon as they are available, and that you always use the latest versions.

**Safety instructions**

- The device may only be operated in a secure environment (intranet or VPN) to which only authorized users have access.
- Under no circumstances must the device be connected directly to the Internet. This applies in particular to ports 80, 137, 138 and 3671.
- Configuration of the device via the Connection Manager should only be done in a secure environment.
- The configuration of the KNX system via the ETS and the IP Control Center (KNXnet/IP) may only be carried out in a secure environment and under no circumstances via the Internet.
- If https is activated, port 443 can be connected to the Internet via port forwarding.
- http communication (HTTP connection status) must not be activated for security reasons.
- For security reasons, the passwords must be changed after commissioning.
- If the device changes ownership, the SMTP password must be changed for security reasons, as it cannot be ruled out that it can be read out of the unit.

Additional Information

<http://www.siemens.com/gamma>

Installation Instructions

The device can be used for permanent interior installations in dry locations within distribution boards or small casings with DIN rail EN 60715-TH35-7.5.

**WARNING**

- The device may only be installed and commissioned by a licensed electrician.
- The relevant safety and accident prevention rules are to be obeyed.
- The device must not be opened.
- When planning and installing electrical systems, the relevant national directives, rules and regulations of the country in question are to be obeyed.

Technical Specifications**Power supply**

- Bus voltage: supplied via the KNX bus line
- Operating voltage: from an external SELV power supply AC/DC 24 V nominal, permissible input voltage range: 12 ... 24 V AC/DC, (for class 2 only),
- Power consumption: max. 1,2 W @ 24 V DC
- Recommended power supplies:

– **LOGO! Power 24 V / 1,3 A**, (class 2),
Rated input voltage AC 100...240 V wide range,
Input voltage range AC 85...264 V,
Constant current supply DC 24 V / 1,3 A,
Rated output voltage: DC 24 V,
Width: 2 SU

– **LOGO! Power 24 V / 2,5 A**,
Rated input voltage AC 100...240 V wide range,
Input voltage range AC 85...264 V,
Constant current supply DC 24 V / 2,5 A,
Rated output voltage: DC 24 V,
Width: 3 SU

– **LOGO! Power 24 V / 4 A**,
Rated input voltage AC 100...240 V wide range,
Input voltage range AC 85...264 V,
Constant current supply DC 24 V / 4 A,

IP Control Center N 152

5WG1152-1AB01

Rated output voltage: DC 24 V,
Width: 4 SU

Network communication

- IP-connection via Ethernet, speed 100 Mbit / second
- IP address allocation via DHCP service or fixed IP address

Connections

- Bus line: Bus terminal (black-red), without screws
0,6...0,8 mm Ø single core
Insulation strip length 5 mm
- Ethernet 100 Mbps, connection: RJ45 socket
- Power supply:
Bus terminal (yellow-white), without screws
0,6...0,8 mm Ø single core
Insulation strip length 5 mm

Control elements

- 1 learning button:
to change between normal and addressing modes

Display elements

- 1 red LED: ERR-LED signals fault status
- 1 yellow LED: LK-LED signals device Ethernet readiness
- 1 red LED: to indicate normal mode / addressing mode

Mechanical specifications

- Dimensions: DIN-rail mounted device,
Width 4 SU (1 SU = 18 mm), height 55 mm
- Fire load: approx. 3.300 kJ
- Weight: approx. 150 g

Electrical safety

- Degree of contamination: 2
- Type of protection (to EN 60529): IP 20
- Protection class: (to IEC 1140) III
- Overvoltage category: III
- Bus: Safety Extremely Low Voltage SELV DC 24 V

Reliability

- Failure rate: 795 fit according SN29500

EMC criteria

- Meets EN 50428:2005 + A1:2007 + A2:2009 and
EN 61000-6-2:2005, EN 61000-6-3:2007 + A1:2011

Environmental specifications

- Climatic conditions: EN 60721-3-3 class 3k5
- Ambient temperature in operation: -5 °C ... + 45 °C
- Storage temperature: - 25 ... + 70 °C
- Relative humidity (non-condensing): 5% to 93%

Marking

- KNX *EIB*

CE mark

Complies with the EMC regulations (residential and functional buildings) and low voltage regulations.

Location and Function of the Display and Operating Elements

Figure 1: Location of the display and operating elements

- A1 DC 24 V bus connector terminal (yellow-white)
- A2 KNX bus connector terminal (black-red)
- A3 Ethernet RJ45 socket
- A4 KNX programming LED
- A5 KNX learning button
- A6 ERR: Error status LED
- A7 LK: Ethernet Activity + Communication LED

IP Control Center N 152

5WG1152-1AB01

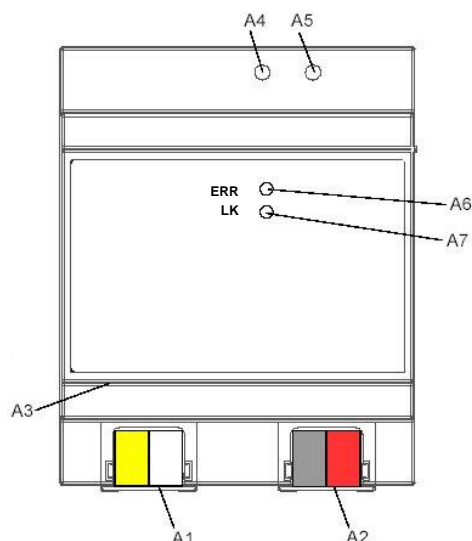
The device connections and the elements needed for KNX commissioning - learning button and programming LED - are accessible in the distribution board only when the lid is removed.

Mounting and wiring

General description

The N-system DIN-rail device can be installed in distribution boards, surface or flush mounted, or on any DIN rail complying with EN 60715-TH35-7,5.

The connection to the bus line is established via the bus connector terminal (red-black) on the top side.

The RJ45 socket on the device front side provides the connection to the Ethernet-IP data network.

Mounting

- Snap the IP Control Center N 152 (Figure 2, B1) on to the DIN rail (Figure 2, B2).
- Connect the auxiliary power AC/DC 24 V with the yellow-white bus connector terminal (Figure 1, A1).
- Connect the bus line with the black-red bus connector terminal (Figure 1, A2).
- Plug an Ethernet patch cable with an RJ45 plug into the RJ45 socket (Figure 1, A3) to connect the device with the LAN/Intranet.

A connection is established to the network when the yellow LED marked LK (Figure 1, A7) is continuously lit.

Dismounting

- Unplug the Ethernet patch cable from the RJ45 socket (Figure 1, A3)
- Remove the yellow-white bus connector terminal (Figure 1, A1) from its socket.
- Remove the black-red bus connector terminal (Figure 1, A2) from its socket.
- Remove the device (Figure 2, C1) with the catcher (Figure 2, C3) from the DIN rail (Figure 2, C2)

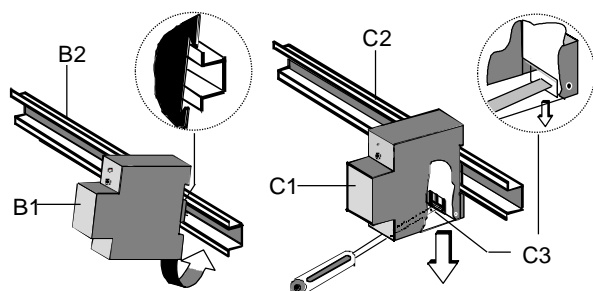

Figure 2: Mounting and dismounting a DIN-rail device

Slipping off bus connection blocks (Figure 3)

- The bus connection block (Figure 3, D2) is situated on the top of the device (Figure 3, D1).
- The bus connection block (Figure 3, D2) consists of two components (Figure 3, D2.1 and D2.2) with four terminal contacts each. Take care not to damage the two test sockets (Figure 3, D2.3) by accidentally connecting them to the bus cable or with the screw-driver (e.g. when attempting to unplug the bus connection block).
- Carefully put the screw-driver to the wire-inserting slit of the bus connection block's grey component and pull the bus connection block (Figure 3, D2) from the device (Figure 3, D1).

Slipping on bus connection blocks (Figure 3)

- Slip the bus connection block onto the guide slot and press the bus connection block (Figure 3, D2) down to the stop.

Connecting bus cables (Figure 3)

- The bus connection block (Figure 3, D2) can be used with single core conductors $\varnothing 0,6 \dots 0,8$ mm.
- Remove approx. 5 mm of insulation from the conductor (Figure 3, D2.4) and plug it into the bus connection block (Figure 3, D2) (red = +, black = -).

Disconnecting bus cables (Figure 3)

- Unplug the bus connection block (Figure 3, D2) and remove the bus cable conductor (Figure 3, D2.4) while simultaneously wiggling it.

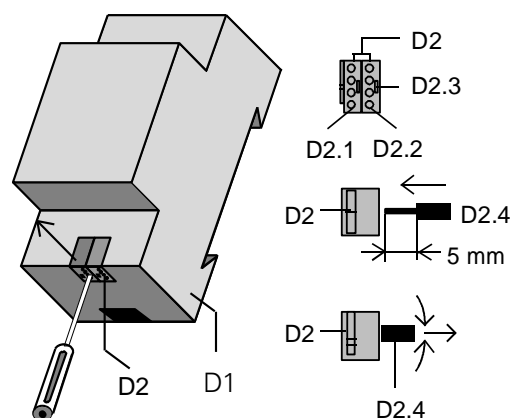

Figure 3: Connecting and disconnecting the bus wires

IP Control Center N 152

5WG1152-1AB01

Slipping off / on auxiliary power connection block

- Follow the instructions for the bus connection block when slipping off/on the auxiliary power connection block.

Dimension Diagram

Dimensions in mm

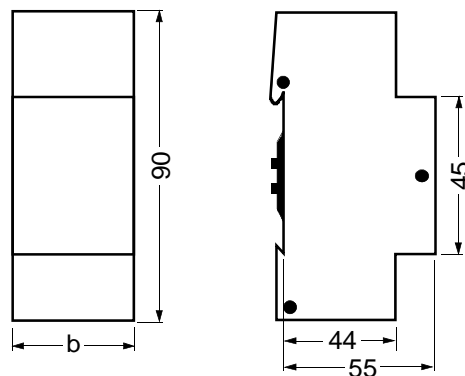

b = 4 SU

1 Standard unit (SU) = 18 mm

General Notes

- The operating instructions must be handed over to the client.
- Any faulty device is to be sent together with a return delivery note of the local Siemens office.
- If you have further questions concerning the product please contact our technical support:

☎ +49 (911) 895-7222

☎ +49 (911) 895-7223

✉ support.automation@siemens.com

www.siemens.com/automation/support-request